

G. M. GUERRANT. ENGRAVING MACHINE.

No. 414,526.

Patented Nov. 5, 1889.

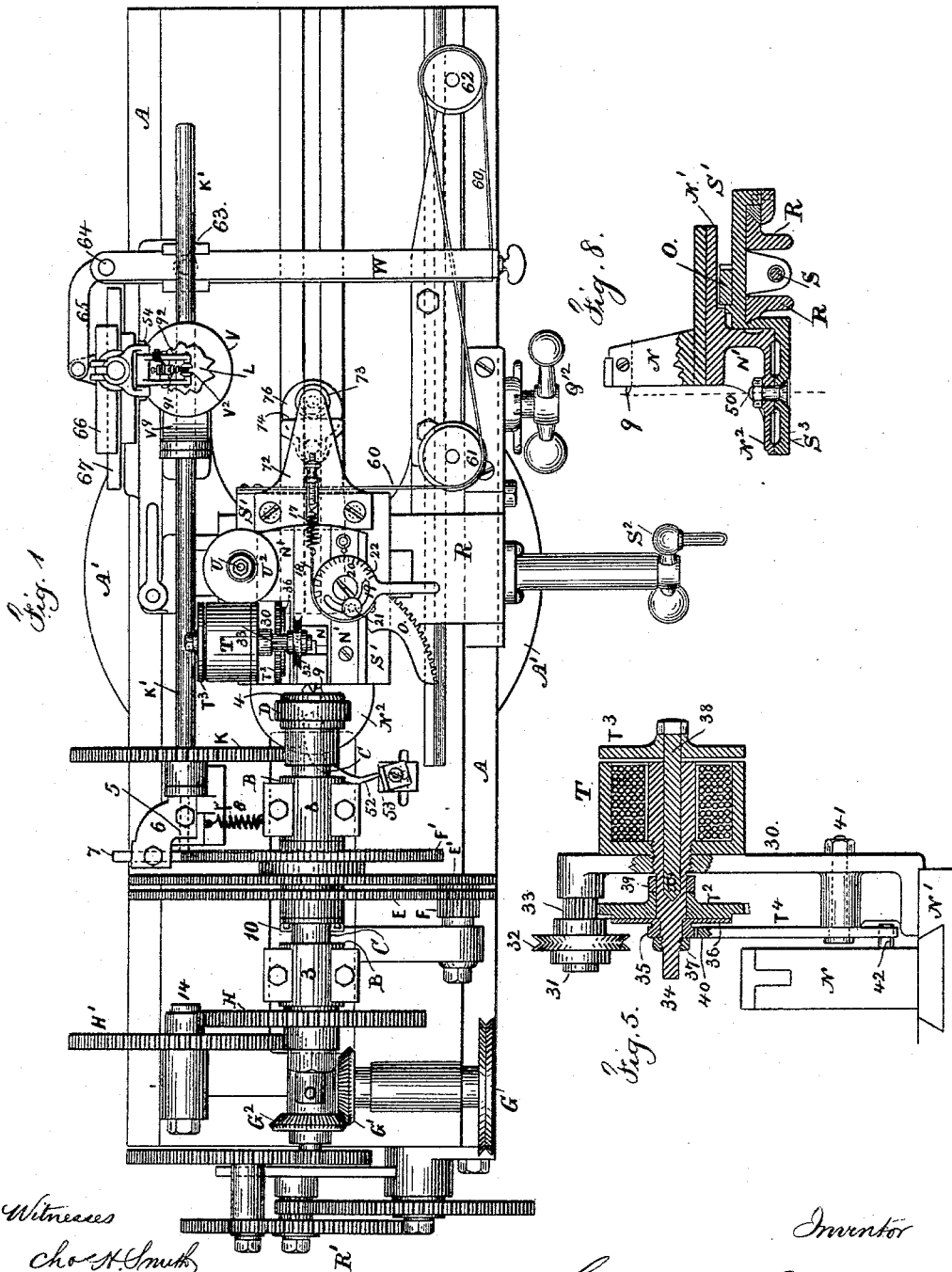

Witnesses
 Chas. H. Smith
 J. Stair

Inventor
 George M. Guerrant
 per Lemuel W. Serrell atty

(No Model.)

G. M. GUERRANT. ENGRAVING MACHINE.

No. 414,526.

Patented Nov. 5, 1889.

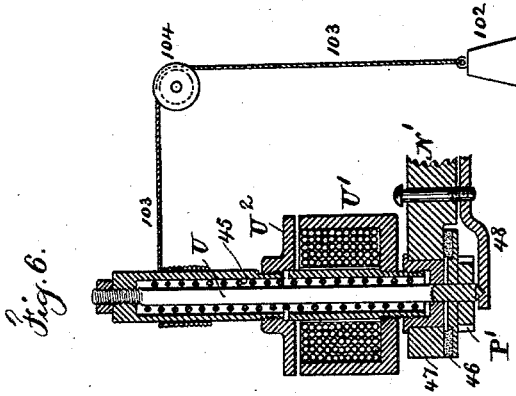

Fig. 6.

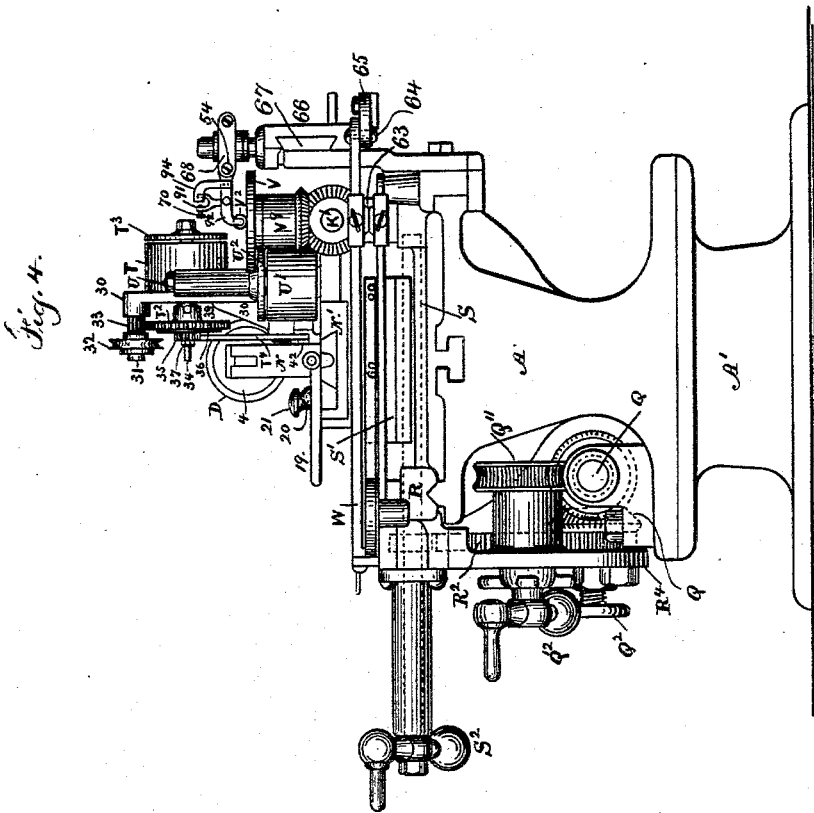

Fig. 4.

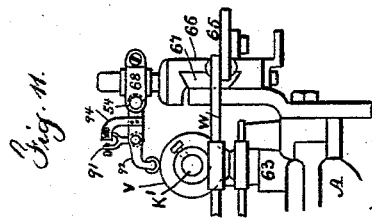

Fig. 11.

Witnesses,

Chas. H. Smith
J. Staib

Inventor

George M. Guerrant
for Lemuel W. Serrell

(No Model.)

4 Sheets—Sheet 4.

G. M. GUERRANT. ENGRAVING MACHINE.

No. 414,526.

Patented Nov. 5, 1889.

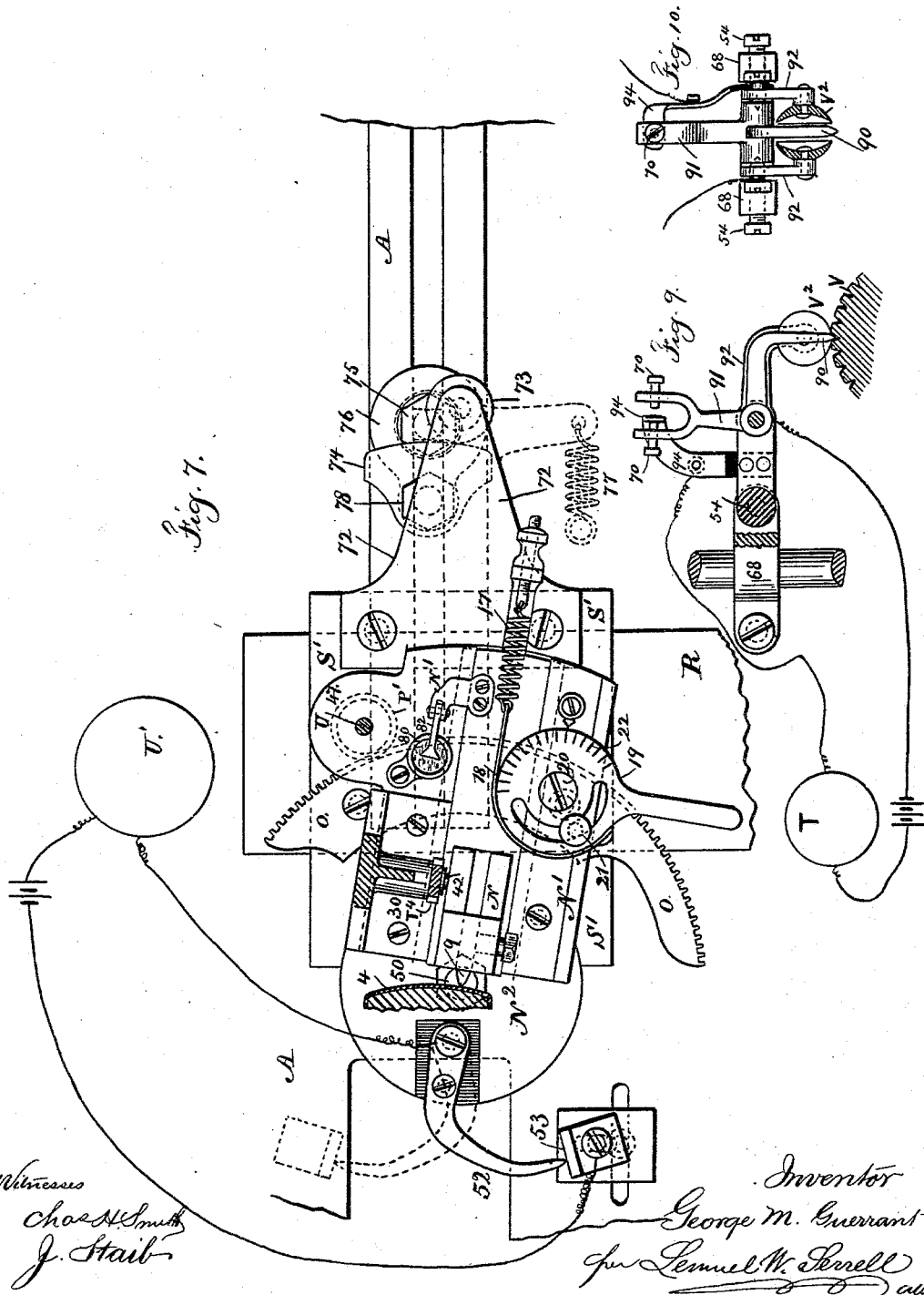

Fig. 7.

Fig. 9.

Fig. 10.

Witnesses
Chas. H. Smith
J. Haib

Inventor
George M. Guerrant
per Lemuel W. Powell atty

UNITED STATES PATENT OFFICE.

GEORGE M. GUERRANT, OF NEW YORK, N. Y.

ENGRAVING-MACHINE.

SPECIFICATION forming part of Letters Patent No. 414,526, dated November 5, 1889.

Application filed May 15, 1889. Serial No. 310,887. (No model.)

To all whom it may concern:

Be it known that I, GEORGE M. GUERRANT, of the city and State of New York, have invented an Improvement in Engraving-Machines, of which the following is a specification.

The object of the present invention is to engrave watch cases or lids or similar articles by a revolving motion, and to produce upon such metallic article ornamentation known as "barley-corn" or engine-turned work or other line ornaments, and this character of ornamentation is interrupted, so as to leave upon the article engraved a blank surface or shape corresponding to a pattern, in order that this blank surface may be engraved by hand or otherwise in designs or patterns; or letters or designs may at the same time be produced by the pattern.

In carrying out this invention the article to be engraved is revolved and it receives a vibrating movement at right angles to the axis of rotation, so that a fine spiral line cut by the engraving-tool may be undulated, and these undulations come together to produce what is known as the "barley-corn" or engine-turned pattern; or the article engraved may receive a movement in the line of the axis of rotation to cause the cut around a cylindrical article to be zigzag for producing the barley-corn or other engraved pattern; and I make use of devices hereinafter described that are electrically controlled for drawing back the engraving-tool and interrupting the pattern at those places where the article that is being engraved is to be left blank, and I provide for rotating the pattern made use of in connection with the electrically-controlled device, and I also provide an electrical controlling device for bringing into action the mechanism that adjusts the position of the engraving-tool to the article being engraved, in order that such engraving-tool may follow around upon a more or less convex surface to be engraved and occupy a position perpendicular, or nearly so, to the particular portion of the surface upon which the engraving-tool is acting.

In the drawings I have represented my improvements as applied to an engine-turning lathe constructed with special reference to adapting the same to the various styles of

engraving and shapes or articles manufactured by watch-case engravers and jewelers; but my improvements are not intended for any special class of manufactured articles that are to be engraved.

In the drawings, Figure 1 is a general plan view of the machine, and Fig. 2 is an elevation thereof. Fig. 3 is a detached view of the bearing for the vibrating yoke. Fig. 4 is an end view of the machine. Fig. 5 is a section of the magnet and mechanism made use of in drawing back the engraving-tool. Fig. 6 is a similar view of the magnet and mechanism made use of in swinging the bed that holds the engraving-tool to keep such engraving-tool perpendicular to the surface that is being engraved. Fig. 7 is a diagrammatic plan view in larger size and partially in section representing the electric circuit and device for breaking the circuit when the engraving-tool is not perpendicular to the surface being engraved. Fig. 8 is a section of the slide-rest and elevation of the tool-stock. Figs. 9 and 10 represent the circuit-closing arms and tracer, and Fig. 11 represents a portion of the machine with the pattern upon the counter-shaft.

The main bed A of the machine is of suitable size and adapted to receive the parts hereinafter described, and this bed is conveniently supported upon a foot A'. The yoke B is supported upon pivots 2 centrally within the bed A, and at the upper ends of the yoke B are the journal boxes or bearings 3 for the mandrel C, at the end of which is a chuck D, of any suitable character, adapted to receive the article 4 that is to be engraved.

Upon the mandrel C is a gear-wheel E, having, say, about two hundred teeth. This gear-wheel is fixed permanently to the mandrel C, and adjacent to such gear-wheel E is a similar gear-wheel E', having, say, two hundred and one teeth, and these two gear-wheels are in constant contact with the pinion F; hence as the mandrel is revolved, as hereinafter designated, the gear-wheel E' is changed in its position to the gear-wheel E one tooth each revolution, and around the mandrel C is a pattern-disk F', fastened to the wheel E' and having as many indentations in its periphery and in one face as there are teeth in the gear-wheel E', and

upon the bed A is a bracket 6, (see Fig. 1,) having a stationary finger 7, against which the pattern-disk is constantly pressed by a spring 8; hence as the mandrel C and gear-wheels E E' and pattern-disk F' are revolved the yoke B, mandrel, and article to be engraved will be vibrated laterally upon the pivots 2 and the line traced by the engraver 9 will be undulating or zigzag, and I remark that this has before been accomplished in engraving-machines by somewhat similar mechanism, and, furthermore, I remark that the mandrel C is free to move slightly in the line of its axis, there being a spring 10 behind a collar upon the mandrel to press the article toward the engraver, and if the finger 7 is placed in the position indicated by dotted lines at 5, Fig. 1, so as to act against the undulations in the face of the pattern-disk F', the mandrel will be vibrated in the line of its axis and the machine will be adapted to the engraving of a cylinder. In consequence of the movement being in the line of the axis of the cylinder, the waving or zigzag line will be cut peripherally upon such cylinder.

I find a convenient train of gearing for revolving the mandrel C and counter-shaft K' to consist of the driving-pulley G, bevel-gears G' G², and a pinion 12, (see Fig. 2,) gearing into the wheel H upon the mandrel and the wheel H' on a gudgeon 14, that gives motion to the pinions I I' and shaft 15, (shown by dotted lines in Fig. 2,) and to the gear-wheel K on the counter-shaft K', and in consequence of the gear-wheels H, H', and K being the same size and the pinions 12 I I' the same size the counter-shaft K' will revolve in unison with the mandrel C, and this counter-shaft K' is to give motion to the pattern L, hereinafter described.

The engraving-tool 9 is supported in a stock N, and this stock N can slide endwise in a bed N', and there is a spring 17, that tends to press the engraver 9 toward the work, and a cord or strap 18 from the end of the spring, passing around a lever-clamp 19, is made use of to vary the force of the spring as it tends to move the tool toward the article that is engraved. This lever-clamp 19 is upon a pivot-screw 20, and provided with a clamp-screw 21, passing through a segmental slot in the lever-clamp, so as to hold such lever-clamp in any position to which it may be adjusted, and the circular portion of the lever-clamp is preferably graduated adjacent to an index 22, so that the power of the spring in its action upon the engraving-tool may be predetermined.

The bed N' may be supported in any suitable manner, and I prefer to make use of the segmental rack O, having rack-teeth upon its edge and fastened to the slide-rest S', and a pinion P' to swing the bed N' upon a center 50, hereinafter described. The segmental rack is described from the center 50 and the point of the engraving-tool directly over it; hence by rotating the pinion P', that is in contact with the teeth at the edge of the seg-

mental rack, the bed N' can be turned around laterally, in order that the center line of the engraver can be vertical, or nearly so, to the article being engraved, and this can be accomplished without varying the pressure of the engraving-tool upon the article that is being engraved. This pinion P' is to be rotated at the proper time by suitable means. I have hereinafter described the electric appliances for accomplishing this object.

It is convenient to make use of the screw Q, running longitudinally of the bed A and acting upon a wheel Q', which also forms a nut when such wheel Q' is clamped by the screw and handle Q²; but when this screw and handle is loosened the wheel can turn without moving the plate R' and the transverse bed R. This device is similar to the device made use of in turning-lathes, and I have represented a train of gearing at R' for giving the motion to this screw Q, the gears in this train of gearing being changeable, as usual in screw-cutting and other lathes, to vary the speed of the screw Q in relation to the mandrel C. By this construction I am enabled to move the transverse bed R to place it in its proper position when engraving is to be performed in the machine, and this also allows the lathe to be used for other purposes, in the manufacture of watch-cases or other articles.

When the wheel Q' is loose, the screw Q can revolve without moving the bed R, and by a train of gearing R² a movement can be given from the screw Q to the transverse screw S, supported by the bed R and acting upon the slide-rest S', and this slide-rest S' supports the segmental rack O, and it will be understood that by revolving the screw Q sufficiently slow the train of gearing R² will give motion to the transverse screw S and slide-rest S' and carry the segmental rack O, bed N', and stock N and engraver 9 gradually across the machine, so that the engraving-tool may be made to commence the engraving in the center of the article and engrave gradually out toward the rim of such article, according to the direction of rotation of the screw S; but I usually prefer to commence the engraving near the rim of the article and to engrave inwardly, and it will be understood that the handle S² upon the end of the screw S may be made use of in adjusting the slide-rest S' transversely of the lathe to bring the engraving-tool to the proper position to commence the engraving.

Having described the general features of this machine, I will now describe the electric appliances for drawing back the engraver whenever the engraving is to be interrupted.

Upon the bed N' is a standard 30, supporting an electro-magnet T, and at the upper end of the standard 30 is a gudgeon 31, supporting the band-pulley 32 and pinion 33, and there is to be a band around this pulley 32 by which such pulley and the pinion 33 are revolved continuously, and this pinion 33

gives motion to a gear-wheel T^2 upon a stud 34, which is a prolongation of the core of the electro-magnet, and upon this stud 34 is a pinion 35 and friction-disk 36, there being a fixed collar 37 to retain the pinion and disk in position. The core of the electro-magnet is hollow and contains the pin 38, that is connected with the armature T^3 , and there is a cross-pin through the pin 38 in a slot in the stud 34, acting against the collar 39, adjacent to the hub of the gear-wheel T^2 . The pinion 35 gears into the rack 40 upon the upper end of the lever T^4 , and this lever is pivoted at 41 and slotted at its lower end to receive the pin 42 upon the stock N, holding the engraving-tool. The friction-surfaces in contact may be ribbed concentrically or made as interlocking clutches of any desired character.

It is now to be understood that the band-pulley 32, pinion 33, and gear-wheel T^2 are constantly revolved; but the friction between the side of the gear-wheel T^2 and the disk 36 is not enough to turn such disk 36 and the pinion 35 until the electro-magnet T is energized, the armature T^3 attracted, and the collar 39 forced against the hub of the wheel T^2 , and the friction thereof against the disk 36 turns the same and the pinion 35 and swings the rack-lever T^4 , and by the pin 42 draws the stock N and engraver 9 back from the work, and when the electric current ceases in the magnet T the spring 17 moves the engraver forward into contact with the article being engraved.

The device made use of for sending an electric current through the helix of the magnet T whenever the engraving is to be interrupted may be of any desired character. That which I have described hereinafter has been found preferable, and it will be understood that should the arrangement of the parts and the direction of the rotation be reversed the tool may be brought up to its position by the frictional contact between the gear-wheel T^2 and the disk 36 and drawn back by a spring, although I prefer the conditions herein set forth.

The device represented in Fig. 6 is adapted to turning the pinion P' , in order to act against the stationary segmental rack O and turn the bed N' progressively and keep the engraver 9 vertical to the surface of the article being engraved. In this case the pinion P' is fastened to the lower end of a vertical shaft U , around which is a helix 45, that forms a spring, and this spring is wound up by rotating the pinion P' as the bed N' is swung laterally, and the helix 45 being fastened at one end to the shaft U and at the other end to a stationary tube surrounding such helix. This stationary tube forms the core of an electro-magnet U' , and U^2 is an armature having a tubular extension containing a part of the spring-helix 45 and fastened at its upper end to the shaft U , and there is upon the pinion P' a friction-disk 46, preferably provided with an annular frictional surface of leather against the under side of the support 47 on

the bed N' . There may be a spring-step 48 for the lower end of the shaft U , and it is now to be understood that the helix 45 is to be coiled up and compressed endwise sufficiently to produce the required friction between the friction-disk 46 and the under side of the support 47, for holding the pinion P stationary in its normal position; but when the electric current is allowed to pass through the helix of the electro-magnet U' the armature U^2 is attracted, and it draws down the vertical shaft U and pinion P' sufficiently to lessen the friction between 46 and 47 and allow the spring-helix 45 to partially rotate the pinion P' and swing the bed N' by the action of the pinion P' against the stationary segmental rack O , and this movement is arrested by the friction between 46 and 47 the moment the electric current is broken.

If the weight 102 is connected with a cord 103, passing over a pulley 104, and wound around the tubular core, as seen in Fig. 6, this weight may be made use of for turning the pinion P' , instead of depending upon the spring 45. In this instance the spring 45 will simply act to keep the frictional surface 46 in contact with 47 for preventing the rotation of the pinion until the electro-magnet is energized.

The device for directing the electric current through the helix of the electro-magnet U may be of any suitable character, but I prefer those hereinafter described, as well adapted to use for the other parts of my machine.

In Fig. 7 the segmental rack, the engraving-tool, and a portion of the supporting parts are represented, the electro-magnet U' being removed from its position around the shaft U and represented in the electric circuit to the battery, the article 4 to be engraved being shown in section.

At one side of the slide-rest S' is a circular bearing S^3 for the circular rest N^2 , that extends outwardly and downwardly from the bed N' , the central bolt 50 uniting the circular rest N^2 to the circular bearing S^3 , being exactly below the point of the engraving-tool, so that this bed N' and rest N^2 can turn upon the bolt 50 into any desired position to the transverse bed R , as the pinion P' may be rotated from time to time and act upon the stationary segmental rack O . (See Figs. 1, 2, and 7.) There is a finger 52 on the circular rest N^2 , which finger is insulated, and to this finger one conductor from a galvanic battery is connected, as indicated in Fig. 7, and the other conductor from the battery is connected to the contact-block 53 on the bed A . As represented in Fig. 7, the engraving-tool is supposed to be cutting from the center outwardly; hence as the slide-rest S' is moved upon the transverse bed R the finger 52 comes into contact with the block 53 and closes the circuit to the electro-magnet U' , and this draws down the shaft U , separating the disk 46 from the support 47, and allowing the pin-

ion P' to be turned by the helical spring 45, and this pinion, acting against the stationary rack O, swings the bed N' into a still further inclined position to keep the engraver 9 perpendicular to the surface of the article 4, and in so doing the circular rest N² is turned and the insulated finger 52 moved away from the contact-block 53, and the circuit is broken, and this operation continues from time to time until the entire surface of the article is engraved.

The position and shape of the contact-block 53 and insulating-finger 52 will be varied according to the shape of the article that is being engraved, and in cases where the engraving-tool commences near the periphery of the article and engraves toward the center the finger 52 will occupy the position indicated by dotted lines in Fig. 7, and the contact-block 53 will be on the other side, as shown by dotted lines.

As before described, the counter-shaft K' makes one revolution for each revolution of the mandrel C, and I communicate a similar movement to the pattern-bed V and pattern L by the bevel-gearing V', and the pattern L upon this pattern-bed V is in relief, corresponding in shape to the shape of the blank space to be left in the engraved article, and over the pattern-bed is a tracer V², hung upon pivots 54. The lower end of this tracer is rounding, and hence it is raised by the relief-pattern L upon the pattern-bed V, and in the movement of the tracer V² the electric circuit is open and closed to the magnet T, as indicated in Fig. 5. Hence, whenever the electric circuit is closed, the engraver 9 is drawn back by the mechanical action of the band-pulley 32, pinion 33, gear-wheel T², and rack-lever T⁴, as before described; but it will be apparent that while the pattern-bed V is revolved once each time the article being engraved is revolved it is also necessary to move the tracer V² laterally across such pattern-bed and pattern in harmony with the movement of the engraving-tool across and in front of the article that is being engraved. To effect this object, I connect to the bed S' a band 60, preferably of thin metal, passing around the pulleys 61 and 62 to the pantograph-lever W, the pivot 63 of which is adjustably supported upon the bed A, and the back end of this pantograph-lever is pivoted at 64 to a link 65, connected to a sliding bed 66, having a V-shaped supporting-bed 67, connected to the main bed A, and at the upper end of this sliding bed 66 is an arm 68, carrying the pivot 54 of the tracer V²; hence, as this slide-rest S' moves across upon the bed R as the feed takes place, the tracer V² is drawn along across the pattern-bed V and pattern, and the proportion of the parts is such that the tracer V² comes to the center of the pattern at the same time that the engraver 9 comes to the center of the article that is being engraved, and the tracer and engraver come to the rim of the article and

the pattern-bed, respectively, at the same time. The fulcrum 63 of the lever W is movable, so that the relative movements can be varied, so that a given pattern can be adapted to a larger or smaller article being engraved.

It is important to be able to engrave upon a cylinder instead of upon a convex plate or watch-case, in which instance the cylindrical article to be engraved will be on the mandrel and the engraver and parts supporting the same will be swung around to occupy the proper position to such cylinder to be engraved, and in this case it is preferable to make the bearing V⁹ for the shaft K' in two parts, as seen in Fig. 2, and to disconnect the pattern-bed V and bevel-gearing and place the cylindrical pattern directly upon the counter-shaft K', as illustrated in the diagram, Fig. 11, and in this case the tracer and the parts carrying the same will be adjusted vertically to accommodate such pattern, the support for the bed 67 being changeable or adjustable, so as to hold such V-bed 67 at the proper height above the main bed A.

In Figs. 9 and 10 the cylinder made use of as a pattern for the tracer is represented as having indentations or slots to allow the tracer to descend, and upon the arm of the tracer is an upright finger 94, between the contact-points 70, to which one wire of the electric circuit is connected, so that the electric circuit can be closed to cause the engraving-tool to be drawn back when the tracer drops into the recess-pattern, or the circuit can be closed to the other contact-screw when the tracer rises to the surface of the pattern. These contact-screws being adjusted according to the character of the pattern and the mode of engraving, it is preferable to make the tracer of two half-balls, there being a space between them for the finger 90, having a V-shaped end to pass down freely, and this finger 90 is on a secondary lever 91, pivoted upon the tracer-arm 92 and having the upward-projecting circuit-closing fork and the contact-screws 70, so that motion is given to the lever 91 by the pattern, and the circuit is closed by one of the screws against the finger 94. This character of tracer and electric contacts can be made use of with the flat pattern-bed or with the cylindrical pattern-bed.

It is to be understood that the electric circuit will be closed between the finger 94 and either one of the screws 70, the other screw being drawn back, and one wire from the battery may either be connected to the tracer, as seen in Fig. 9, or it may be connected to the pattern; but, if desired, the pattern may be made of non-conducting material, and the cylinder or surface upon which it rests may be made of conducting material, so that the circuit will be broken by the pattern itself.

In Figs. 1 and 7 I have represented a bracket 72, attached to the slide-rest S' and extending to the rear and having a roller 73 adjacent to an adjustable pattern-holder 76, held upon the bed A by a clamping-nut and screw 75 in

the grooved surface of such bed. The pattern 74 is clamped by the screw 78 to the holder 76, and the object of this pattern 74 is to move the beds R and S' longitudinally of the lathe as the bed S' is moved transversely by the action of the feeding-screw, thereby causing the engraver 9 to cut into the article being engraved the proper distance, as the pattern 74 is to correspond to the sectional shape of the article that is being engraved. I have shown by dotted lines in Fig. 7 a spring at 77 for keeping the roller 73 against the pattern 74, the spring being attached at one end to the bracket 72 and at the other end to the bed A.

It is usually preferable to provide a stop-motion for stopping the lathe at the ends of each operation. This may be of any desired character.

I find that in some instances the spring 17 is liable to project the stock N and the engraving-tool 9 too rapidly, and where the engraving-tool is a diamond it is sometimes injured by the sudden concussion thereof against the metal. To avoid this difficulty, I place upon the bed N' a small cup 80, which is to contain molasses or other viscid liquid, and upon the stock N, I place a hinged arm 82, having a flat or nearly flat end, and the parts are so placed that the stock N and arm 82 can be drawn back easily; but as the stock and engraver are moved toward the article the viscid liquid between the end of the arm and the side of the cup forms a yielding buffer, the liquid being pressed out laterally and forming a sufficient resistance to prevent the blow of the engraver upon the article being engraved. The arm and cup are adjustable, so that the space occupied by the resisting viscid liquid can be greater or less to regulate the buffing or stopping action.

I claim as my invention—

1. The combination, with the mandrel for revolving the article to be engraved, of an engraving-tool, a stock for holding the same, a revolving pinion, and mechanism for withdrawing the engraving-tool, and a pattern revolving in unison with the article to be engraved, and a tracer and circuit-closer, and an electro-magnet for bringing into action the withdrawing mechanism, substantially as set forth.

2. The combination, with a revolving mandrel for holding the article to be engraved, of an engraving-tool, a sliding stock for holding the same, an electro-magnet, a pattern and a circuit-closer acted upon by the pattern, a revolving friction device, and mechanism brought into action by the electro-magnet for withdrawing the engraving-tool, substantially as set forth.

3. The combination, with the engraving-tool and the holder for the same, of an electro-magnet, means for opening and closing the circuit to the same, a wheel revolved mechanically, and a friction device acted upon

by an electro-magnet for withdrawing the tool, substantially as set forth.

4. A mandrel for holding and revolving the article to be engraved, a pattern-disk and finger for vibrating the mandrel laterally or longitudinally, or both, in combination with an engraving-tool, and an electro-magnet, and a circuit-closing device controlled by a pattern, and mechanism, substantially as specified, between the electro-magnet and the engraving-tool brought into action by the electro-magnet for withdrawing such engraving-tool in harmony with the pattern, substantially as set forth.

5. The combination, with the mandrel for holding and revolving the article to be engraved, of an engraving-tool, a stock for the same, a bed for supporting the stock, a segmental rack and a pinion connected with the bed for swinging the bed and the tool and maintaining such tool in a perpendicular or nearly perpendicular position to the surface being engraved, and an electro-magnet and circuit-connections for automatically actuating the pinion, substantially as set forth.

6. The combination, with the mandrel for holding and revolving the article to be engraved, of an engraving-tool, a stock for the same, a bed in which the stock can slide, a revolving pinion and lever for drawing back the stock and tool, an electro-magnet for bringing the lever into action, the segmental rack and pinion for turning the stock and bed laterally, and an electro-magnet and spring for controlling the action of the pinion in its operation upon the bed, substantially as set forth.

7. The combination, with the tool and its stock and bed, of a segmental rack and pinion for swinging the bed and tool laterally, a spring for rotating the pinion, a friction-disk for preventing the pinion from turning, and an electro-magnet to relieve the friction and permit the spring to turn the pinion, substantially as set forth.

8. The combination, with the engraving-tool and the stock and beds for supporting and moving the same, of a revolving pattern, a tracer, pivots, and a sliding bed, a lever for moving the bed, and a band extending from the lever to the tool-supporting slide, whereby the tracer and tool are caused to move in harmony, substantially as set forth.

9. The combination, with the pattern, of a tracer, a circuit-closing arm acted upon by the pattern, electric-circuit connections, and an electro-magnet in the circuit, the engraving-tool, and a continuously-revolving pinion and mechanism, substantially as specified, between the engraving-tool and the electro-magnet and brought into action by such magnet for withdrawing the engraving-tool in harmony with the pattern that acts upon the tracer, substantially as set forth.

10. The combination, in a lathe for engraving, of a mandrel for holding and rotating

the article to be engraved, mechanism for moving the article and mandrel laterally to produce a zigzag or waving engraved line, an engraving-tool and holder for the same, a pattern revolved in unison with the article to be engraved, circuit-closing devices acted upon by the pattern, and an electro-magnet and connection between the same and the engraving-tool for moving the engraving-tool in harmony with the pattern, substantially as set forth.

11. The combination, with the engraving-

tool, of continuously-revolving mechanism for moving the engraving-tool into and out of contact with the article to be engraved, a pattern, a tracer, an electric circuit, and an electro-magnet brought into action by the tracer and controlling the mechanism that moves the engraver, substantially as set forth.

Signed by me this 7th day of May, 1889.

GEO. M. GUERRANT.

Witnesses:

GEO. T. PINCKNEY,
WILLIAM G. MOTT.